



**Distributed Energy Resources
Connection Procedures
Version 1.0**

Release Date: March 22, 2022

Distributed Energy Resources Connection Procedures

Table of Contents

1. Purpose.....	4
2. Definitions	4
3. Distributed Energy Resources Connection Procedures Overview	5
4. Preliminary Consultation	6
4.1. Description	6
4.2. Restricted Feeder Lists	6
4.3. Preliminary Consultation Information Request.....	6
4.4. Preliminary Consultation Report	6
5. Connection Impact Assessment	8
5.1. Description	8
5.2. Application forms	9
5.3. Processes	11
5.3.1. Micro Embedded Generation Facilities	11
5.4. Processes for Small, Mid-Sized, and Large Embedded Generation Facility Projects	16
5.5. Screening Process for Small, Mid-sized, and Large Embedded Generation Facility Projects.....	16
5.6. Small Embedded Generation Facility	21
5.5. Mid-sized / Large Embedded Generation Facility	25
6. Agreements	29
6.1. Connection Agreement	29
6.2. Connection Cost Agreement	29
6.3. Connection Cost Responsibility (CCR)	32
6.4. Option to Request a More Detailed Cost Estimate	32
6.5. Build and Energization Process.....	32
7. Glossary	36
8. Appendices	38

Table of Figures

- Figure 1: Distributed Energy Resources Connection Process..... 5
- Figure 2: Flowchart of Timelines and Responsibilities for Micro Embedded Generation Facility Connection ... 12
- Figure 3: Flowchart for Screening Process to Check that an Application is Substantially Complete 18
- Figure 4: Flowchart of Timelines and Responsibilities for Small Embedded Generation Facility Connections .. 22
- Figure 5: Flowchart for CIA process for Mid-sized and Large Embedded Generation Facility Connections..... 26
- Figure 6: Flowchart Outlining Interactions Between Parties (Multiple Connection Agreements) 30
- Figure 7: Flowchart for Build Process 33
- Figure 8: PCC vs PODC (No New Distributor-Owned Line Expansion)..... 36
- Figure 9: PCC vs PODC (With New Distributor-Owned Line Expansion) 37

1. Purpose

The Distributed Energy Resources Connection Procedures (DERCP) document is a consolidation of the procedures, timing, workflows, and template forms issued by the Ontario Energy Board (OEB) to facilitate the communication and implementation of a standardized procedure for the connection of distributed energy resources (DERs) to distribution systems.

The provisions of the DERCP are given force by requirements of Chapters 3 and 6 of the Distribution System Code (DSC) as noted throughout. Compliance with the DSC is a condition of the OEB's Electricity Distributor Licence. Pursuant to the *Ontario Energy Board Act, 1998*, OEB codes, including the DSC, may incorporate by reference, in whole or in part, any standard, procedure or guideline. In case of any conflict between the DERCP and the Code, the provisions of the Code shall govern.

2. Definitions

All definitions in Section 1.2 of the DSC are adopted and apply in the DERCP. The most relevant definitions in the context of the DERCP are: Emergency Backup Generation Facility, exporting connection, non-exporting connection, restricted feeder, and system power.

For the purposes of the DERCP the following definitions also apply:

Applicant

An applicant means a person who approaches a distributor and requests to connect or information to connect a DER to a distributor's system.

Connection Impact Assessment (CIA)

A connection impact assessment means a study performed by or on behalf of the distribution company to assess the impact of a proposed DER connection on its system. The CIA will specify technical requirements for the connection.

Distributed Energy Resource (DER)

Distributed Energy Resource (DER) means, for the purposes of the DERCP, an electricity source or load that is connected to a distribution system, typically through a connection on the customer-side of an ownership demarcation point. Sources generate electricity (e.g. generation facilities, including energy storage facilities when discharging), while loads do not generate electricity (e.g. energy storage facilities when charging).

3. Distributed Energy Resources Connection Procedures Overview

The DERCP applies to the connection of DERs with a generating facility (including DERs with a storage facility) to a distribution system. Throughout the DERCP the term “generating facility” includes energy storage facilities. When an energy storage facility is in discharge mode, it is treated the same as a generating facility. When an energy storage facility is in charging mode, it is treated the same as a load. The DERCP applies regardless of whether the connection is expected to be exporting energy to the grid or non-exporting as both types of generation facilities contribute to short circuit current through the connection under fault conditions. For emergency backup generation facilities, customers are referred to their respective distributor’s websites for information on connection requirements.

From the distributor’s perspective, the connection process can be broken into 4 main stages once an applicant approaches the distributor for a connection. The DERCP provide process flowcharts, information requirements and template forms regarding interaction between applicants and distributors for the 4 stages.

- a. Preliminary consultation, exchange of information and capacity check
 - Planning, information exchange, capacity check
- b. Connection Impact Assessment
 - Capacity allocation
- c. Project Development
 - Project scope and cost
 - Connection Cost Agreement
- d. Build and energization
 - ESA Review and Inspections.
 - Build and Commissioning
 - Connection Agreements



Figure 1: Distributed Energy Resources Connection Process

A distributor is required by Section 6.2.3 of the DSC to maintain a location on its website that serves as a centralized repository for all the information, forms and instructions, including information on applicable fees, necessary for an applicant to apply for connection to the distributor’s system.

4. Preliminary Consultation

4.1. Description

During the initial planning phase of a project, an applicant needs to know if there are any limitations that would prevent connecting a project at a specific location on a distributor's distribution system. The DERCP provides template forms in Appendix C that a distributor must make available to an applicant pursuant to section 6.2.9 of the DSC. The applicant completes and submits a Preliminary Consultation Information Request form to the distributor. The distributor in turn responds with a Preliminary Consultation Report. A Preliminary Consultation Report is not required in order to apply for a Connection Impact Assessment. However, applicants will be expected to submit a complete Connection Impact Assessment application form, including connection information as would otherwise be provided in the Preliminary Consultation Report.

4.2. Restricted Feeder Lists

A distributor will, in accordance with the requirements of the DSC:

- a) Maintain a list¹ of feeders that it owns that have no additional short circuit capacity to accommodate a DER connection.
- b) A feeder should be included on the list whether the constraint is within the distributor's system or caused by limitations upstream in the host utility or transmitter's system.
- c) The distributor will update the list if the system changes or at least every 3 months.

4.3. Preliminary Consultation Information Request

The Preliminary Consultation Information Request (PCIR) form gathers basic information on the proposed project: contact information; project intent, size, type, and location. Through the DERCP, the OEB is providing templated forms to standardize the means by which this information is to be collected. The template form is included in Appendix C to the DERCP.

4.3.1. Where the distributor needs to add to the template PCIR form in response to unique characteristics of its system or operational needs, the distributor will advise the OEB of the changes.

4.3.2. A distributor may establish a web-based interface for the purpose of collecting this information, provided the web-based interface is consistent with Appendix A or is amended in accordance with section 4.3.1.

4.4. Preliminary Consultation Report

The Preliminary Consultation Report (PCR) is provided by the distributor to the applicant and identifies the feasibility of a connection based on the information provided in the PCIR and the distributor's knowledge of available capacity at the proposed point of connection. The Preliminary Consultation Report will identify:

- i. If there is no possibility of connecting the project due to short circuit limitations

¹ A distributor may use an interactive tool to allow applicants to check feeder capacity for a restricted feeder.

- a. at the distribution level; or
 - b. at the transmission level.
- ii. That there may be connection capacity at the location subject to the completion of a CIA.

The distributor must respond to a PCIR within 15 days of receipt of a PCIR as per Section 6.2.9.1 of the DSC.

If the PCR identifies the response as (ii) above, (i.e. there may be connection capacity), it will provide information that the applicant will need to prepare for a CIA application. Any other information that the distributor considers helpful to the applicant in deciding whether to proceed to the next stage of planning (e.g., any conditions on capacity or configuration and the likelihood that the project will require transfer trip), is to be included in the notes section of the PCR. The PCR will also identify what connection studies will be required at the CIA application stage. Depending on the size and location of the project, these may include multiple CIAs (e.g. the distributor and the host distributor), as well as a connection study from the transmitter, and possibly a System Impact Assessment from the IESO.

It is important to remember that the PCR is a snapshot in time and does not reserve capacity for a project.

5. Connection Impact Assessment

5.1. Description

The next stage for the connection of a DER is the CIA. This is a study prepared by the distributor that assesses the steady state and transient reliability and stability impacts of the project at the specific location on the distribution system. The information requirements at this stage are more substantial than the preliminary consultation phase; nonetheless, applicants are cautioned that completion of a CIA does not constitute approval of the protection philosophy and single line diagram (SLD) by the distributor. The protection philosophy and SLD will be subject to distributor review after the CIA has been issued.

Depending on the size of the project and its location within the distribution system, an additional CIA by a host distributor and/or transmitter, and/or a System Impact Assessment by the IESO may also be necessary to assess upstream system impacts. The PCR will identify for the location specified in the PCR the number of additional studies required. Table 1 outlines an anticipated number of additional studies required based on DER classification.

Table 1: Connection Classifications for Processing

DER Classification	Rating	Sample List of Studies
Micro	≤ 10 kW	None
Small	(a) ≤ 500 kW connected on distribution system voltage < 15 kV (b) ≤ 1 MW connected on distribution system voltage ≥ 15 kV	1. Distributor (or Embedded Distributor) 2. Host Distributor (if applicable)
Mid-Sized	(a) ≤10 MW but > 500 kW connected on distribution system voltage < 15 kV (b) > 1 MW but ≤ 10 MW connected on distribution system voltage ≥ 15 kV	1. Distributor (or Embedded Distributor) 2. Host Distributor (if applicable) 3. Transmitter (if applicable)
Large	> 10 MW	1. Distributor (or Embedded Distributor) 2. Host Distributor (if applicable) 3. Transmitter 4. IESO System Impact Assessment

In response to a successful CIA application (where the connection is deemed possible),

- 5.1.1. The distributor will provide the applicant with the technical requirements for connection to the distributor's system
- 5.1.2. The distributor will provide an estimate of the cost to facilitate the connection
- 5.1.3. The distributor will reserve capacity on its own system for a minimum of 180 days² pending a decision by the applicant on moving forward.

Detailed Cost Estimate

As noted in section 5.1.2 above, the CIA will include an estimate of the anticipated connection costs.

Upon receipt of the CIA, an applicant for a mid-sized or large generation facility has the option to request a detailed cost estimate from the distributor prior to entering into a Connection Cost Agreement.

- 5.1.4. To obtain a detailed estimate, the applicant must make a written request for the estimate; the distributor and applicant may enter into a study agreement for the preparation of the cost estimate, if required; the applicant would pay the distributor's fee for preparation of the detailed cost estimate; and the distributor would proceed with preparing the detailed cost estimate. The detailed cost estimate would be provided to the applicant before the applicant signs the Connection Cost Agreement.

5.2. Application forms

In accordance with DSC sections 6.2.5 and 6.2.11, the distributor must make the connection agreement for micro-embedded generation facilities and the CIA application form for all other generation facilities available on its website and in hard copy at its offices. It is preferable for applicants to be able to fill in and submit these forms electronically through email or the distributor's website. To facilitate timely and near concurrent processing of the application, applicants are encouraged to provide payment for all required studies with the application (i.e. study payments for distributor, host distributor/transmitter and IESO if required). Distributors will require payment before commencing studies. The distributor will identify on its website and in the application package the relevant study fee charges.

Micro Embedded Generation Facility

To apply for a connection of a micro-embedded generation facility, an applicant will submit to the distributor a copy of the Micro-Embedded Generation Facility Agreement, in the form provided in Appendix E of the DSC. The applicant will provide the relevant information on the connection agreement and submit it to the distributor. If requested by the distributor, the applicant shall also provide an SLD and generator specification and connection information as required. The distributor may establish and use its own intake form for processing micro-embedded generation facility connection applications, but any agreement between the distributor and the applicant for the connection of the micro-embedded generation facility must be in the form provided in Appendix E of the DSC. The distributor will assess the project and, if approved for connection, sign the connection agreement, and proceed with the connection.

² DSC section 6.2.4.1 provides durations for capacity allocations to be reserved.

Small / Mid-sized / Large Embedded Generation Facility

For all other categories of projects, distributors must use the CIA Application template form provided by the OEB in Appendix B. The expectation of the OEB is that the distributor will only need to add its contact information to the template prior to deploying the form. If unique characteristics of a distributor's system require the distributor to make additions to the template form, beyond the designated distributor-specific sections, then the revised form must be filed with the OEB.

5.3. Processes

5.3.1. Micro Embedded Generation Facility

Micro-embedded generation facilities are equal to or less than 10 kW and are considered to pose a relatively low connection risk to the distribution system compared to larger generation facilities. The process flowchart is outlined below in *Figure 2: Flowchart of Timelines and Responsibilities for Micro Embedded Generation Facility Connection*. The distributor (in accordance with Section 6.2.6 of the DSC) and applicant are expected to follow the process steps outlined below.

DER Connections: Micro-embedded Generation Facility ≤10kW

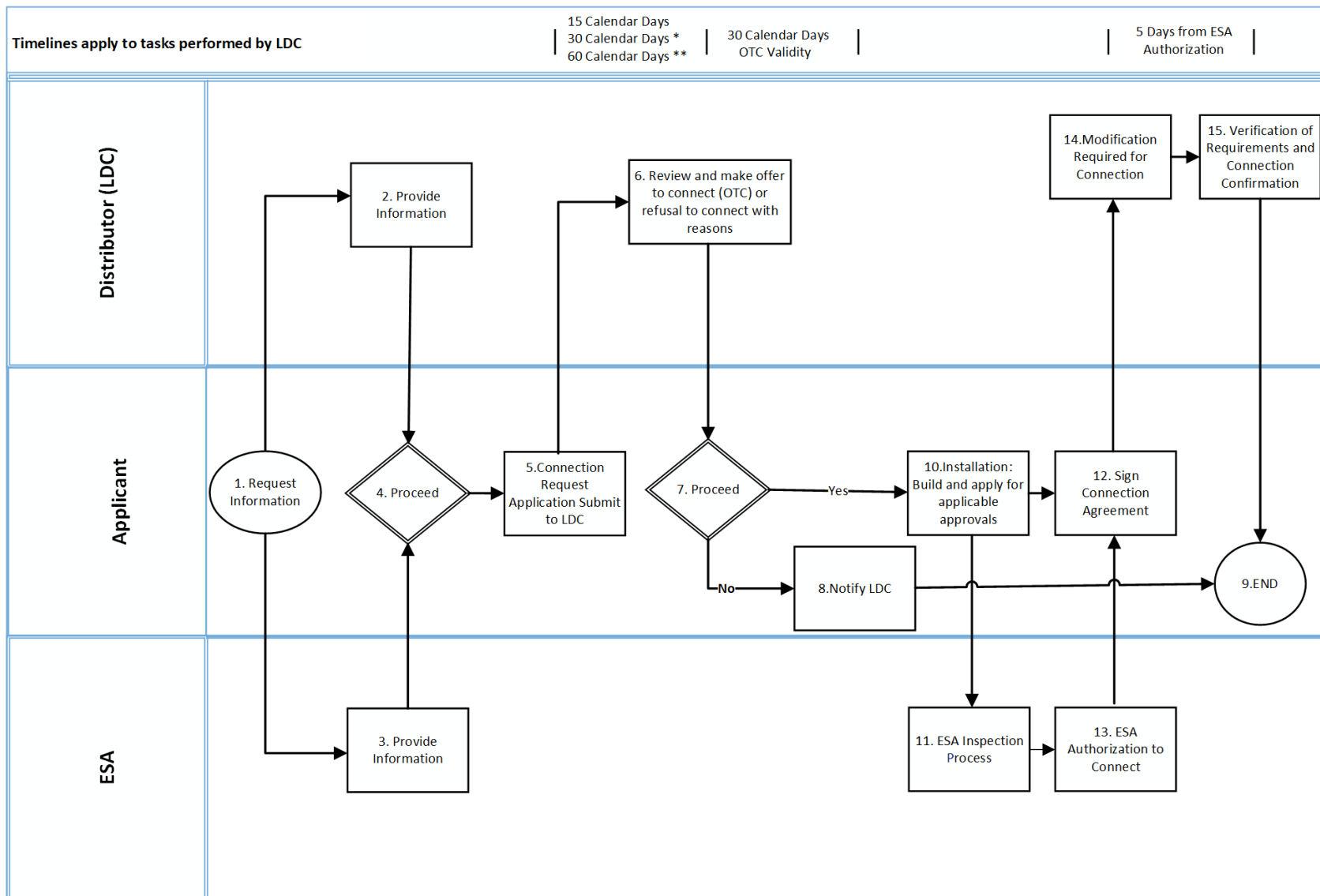

* If at existing connection and site assessment needed

**If not located at existing customer connection

Figure 2: Flowchart of Timelines and Responsibilities for Micro Embedded Generation Facility Connection

Step 1 The applicant proposing the installation of a micro-embedded generation facility with a non-exporting connection contacts the distributor and the Electrical Safety Authority (ESA) to gather connection and process information.

Step 2 The distributor makes the information available to the applicant in a timely manner. The information package will include the description of the connection process approvals needed by the distributor for connection; technical requirements including metering; contractual requirements (Micro-Embedded Generation Facility Connection Agreement); and application forms.

Step 3 ESA provides information on Electrical Safety Requirements

Step 4 The applicant reviews relevant information from the distributor and the ESA on the project, and prepares:

- an installation plan, including the size/type of generation facility (i. e. load displacement/net metering/isolated from distribution system/grid connection); and
- a project plan.

Step 5 The applicant submits application to the distributor to review

Step 6 The distributor makes an offer to connect the approved DER or provides its refusal to connect with reasons within 15 calendar days

The distributor's review of an Application submitted for the connection of a micro-embedded generation facility at the existing customer connection will include:

- typical requirement for new meter only;
- check for service upgrade requirement;
- check for significant amount of other generation on feeder;
- response to the applicant with an offer to connect or refusal
- response to applicant with requirements specific to the connection (typically requirements for metering) and costs, timing to implement, etc.

Step 7 The applicant decides whether to proceed with the connection process.

Step 8. The applicant notifies the distributor that it has decided not to proceed with the connection application.

Step 9. The applicant ends the process.

Step 10 The applicant must indicate its intention to connect within the 30-day validity period of the offer to connect. The applicant must work closely with the distributor, the ESA and any other organizations from which work, inspections, approvals, or licenses are required to prevent delays.

The activities will be planned in coordination with project milestones, and it is up to the applicant to initiate actions at the required times.

Step 11 Where required by the ESA, the applicant must file a notification to receive an ESA Authorization to Connect

Step 12 The applicant reviews and signs the Connection Agreement

Step 13 ESA provides an Authorization to Connect when the installation meets all the applicable requirements of the Ontario Electrical Safety Code as determined by ESA.

Step 14 The distributor completes any work required to facilitate the connection to the distribution system

Step 15 The distributor works with the applicant to complete the connection including any testing and verification requirements

- 5.3.2. For an existing customer connection where a site assessment is not required, the distributor will make an offer to connect within 15 days of receiving a completed application or provide reasons for refusing to connect.
- 5.3.3. The distributor will not charge to prepare the offer to connect outlined in section 5.3.2 above.
- 5.3.4. For new projects where a site assessment is required, the distributor will make the offer to connect within 60 days of receiving a completed application or provide reasons for its refusal.
- 5.3.5. In all cases, the offer will be open for 30 days after it is provided after which it may be revoked by the distributor.
- 5.3.6. If a site assessment is needed, the distributor may charge a \$500 connection deposit for preparing the offer to connect, which shall be payable in the form of cash, cheque, electronic funds transfer, letter of credit from a bank, or surety bond.
- 5.3.7. If the distributor refuses the connection after a site visit, it will return the deposit within 30 days.
- 5.3.8. If the DER applicant does not accept the offer or withdraws its application, the distributor will keep the deposit.
- 5.3.9. If actual connection costs are less than the deposit, the distributor will refund the difference when the connection is completed and in service.
- 5.3.10. Interest shall accrue monthly on connection deposits made by way of cash or cash equivalents commencing on receipt of the total deposit required by the distributor. The interest rate shall be at the Prime Business Rate as published on the Bank of Canada website less 2 percent, updated quarterly. Refunds, in whole or part, of deposits made in cash or cash equivalents will include interest on the refunded amount from the date of receipt.

- 5.3.11. A DER applicant must notify the distributor that it has satisfied all applicable service conditions and received all necessary approvals including confirmation of issuance of the authorization to connect from the ESA.
- 5.3.12. The applicant must enter into a Connection Agreement and pay the required connection costs, including costs for any necessary new or modified metering.
- 5.3.13. Once these conditions have been satisfied, the distributor shall connect the DER applicant's micro-embedded generation facility to its distribution system within 5 business days, or at such later date as agreed to by the DER applicant and the distributor.
- 5.3.14. The distributor must meet the five-day requirement for connection 90 percent of the time on a yearly basis.

5.4. Processes for Small, Mid-Sized, and Large Embedded Generation Facility Projects

The processes for small, mid-sized, and large embedded generation facilities are similar with the difference primarily being the number of impact assessments that may be applicable. Unlike the micro-embedded generation facility process, the connection process for small, mid-sized, and large embedded generation facilities includes a common screening process on application intake.

5.5. Screening Process for Small, Mid-sized, and Large Embedded Generation Facility Projects

CIA applications are subject to a review for completeness, i.e. a screening process. The screening process is intended to provide feedback to the applicant early in the process on any deficiencies in their submission that would prevent a distributor from proceeding with a review. Upon submission of an application, the distributor confirms if the application is substantially complete. A substantially complete application is a submission in which there is sufficient information provided for the distributor to process the application and complete the CIA. To aid an applicant in determining the information requirements that a distributor would typically deem as being sufficient information, a sample application package has been provided in the Appendix C(vii).

The sample application package includes:

- Completed application
- Single line diagram sample
- Protection philosophy sample
- Submission checklist

In order to facilitate timely processing of applications, payment³ for the applicable studies should be included with the submission when possible. The fees for required studies and assessments should be identified on the distributor's website and in the Preliminary Consultation Report.

If the application is incomplete, the distributor will return the incomplete part of the application package to the applicant with a deficiency notification identifying the error and omissions in the application. Upon receipt of a deficiency notification, an applicant should review and correct the application and resubmit the revised application within 14 days. If the application is not returned in 14 days, the application may lose its position in the processing queue.

Upon receipt of a revised CIA application, the distributor must review the application within 7 days to determine if there is sufficient information for the distributor to process the application. If there is sufficient information, the submission is deemed substantially complete and the distributor will reconfirm that the distribution and transmission capacity that was available at the PCR stage is still available. Please note that capacity is not reserved until the CIA is completed. If capacity is available, the application is added to the processing queue and the distributor will proceed with a CIA. This begins the 60-day window for the distributor to return the completed CIA to the DER applicant.

The process flowchart for determining the status of an application using the screening process is outlined in *Figure 3: Flowchart for Screening Process to Check that an Application is Substantially*

³ Distributors are to identify required study cost in the Preliminary Consultation Report.

Complete. The corresponding procedure steps for the distributor and applicant to follow are outlined below the flowchart.

Connection Impact Assessment: Screening Process

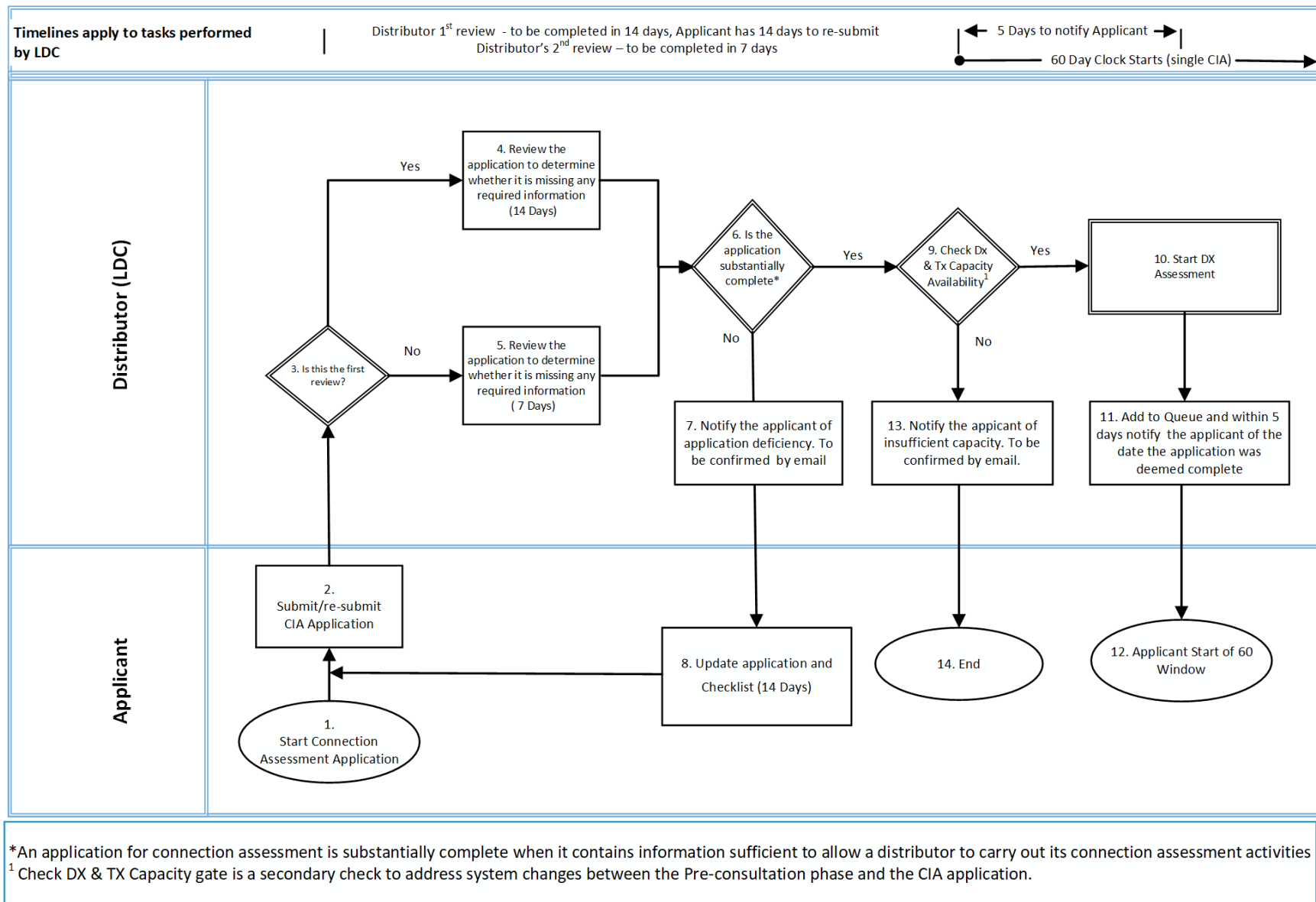

Figure 3: Flowchart for Screening Process to Check that an Application is Substantially Complete

Step 1. The applicant initiates the CIA Application and gathers the current application form and Distributor's application requirements.

Step 2. The applicant submits the completed CIA Application package, including completed application form, payment for required studies, attachments, and application checklist.

Step 3. The distributor determines if this is the initial submission or a revised application submission.

Step 4. For initial submissions, the Distributor reviews the application for completeness within 14 calendar days.

Step 5. For revised application submissions, the Distributor reviews the application for completeness within 7 calendar days.

Step 6. For the completeness check outlined in steps 4 and 5 above, the distributor will review the application to determine if there is sufficient information provided by the applicant to process the submission. Once the distributor determines that the submission provides the necessary information to commence a CIA study, the application is deemed substantially completed.

Step 7. For submissions that are not substantially complete, the distributor will notify the applicant of the application deficiencies via email or letter if the applicant's email is not provided. The deficiency notification shall identify any errors and omissions in the application that would prevent the distributor from proceeding with the CIA. The notification shall outline the available remedies required to have the application deemed substantially complete.

Step 8. On receipt of a deficiency notification, an applicant should review and revise the application to address the deficiencies and resubmit the application. The process allows 14 days for the applicant to resubmit a revised application. If the applicant does not return the revised application within 14 days, the distributor may remove the application from the processing queue. If the application is removed from the queue, it may be treated as a new application once it is resubmitted.

Step 9. For submissions that are deemed substantially complete, the distributor will reconfirm⁴ transmission and distribution capacity availability.

Step 10. If capacity is confirmed to be available, the distributor proceeds with the assessment.

Step 11. The distributor will add the application to the processing queue in the order in which they are deemed substantially complete and within 5 days notify the applicant of the date the application was deemed substantially complete.

⁴ This is a secondary check to address the possibility of system changes between the Preliminary Consultation phase and the CIA application.

Step 12. The date the submission is deemed substantially complete starts the timed-day window for the distributor to send the completed connection impact assessment to the applicant and proceed with the connection agreement.

Step 13. If available capacity is not confirmed, the distributor will notify the applicant via email that capacity is not available to support the connection

Step 14. If there is no capacity available, the process concludes.

5.6. Small Embedded Generation Facility

The screening process ends when the application is deemed to be substantially complete. i.e., there is enough information to begin processing the CIA. The process flowchart is outlined in Figure 4: Flowchart of Timelines and Responsibilities for Small Embedded Generation Facility Connection. The corresponding procedure steps for the distributor and applicant are outlined below the flowchart.

Connection Impact Assessment Process for Small Embedded Generation Facility

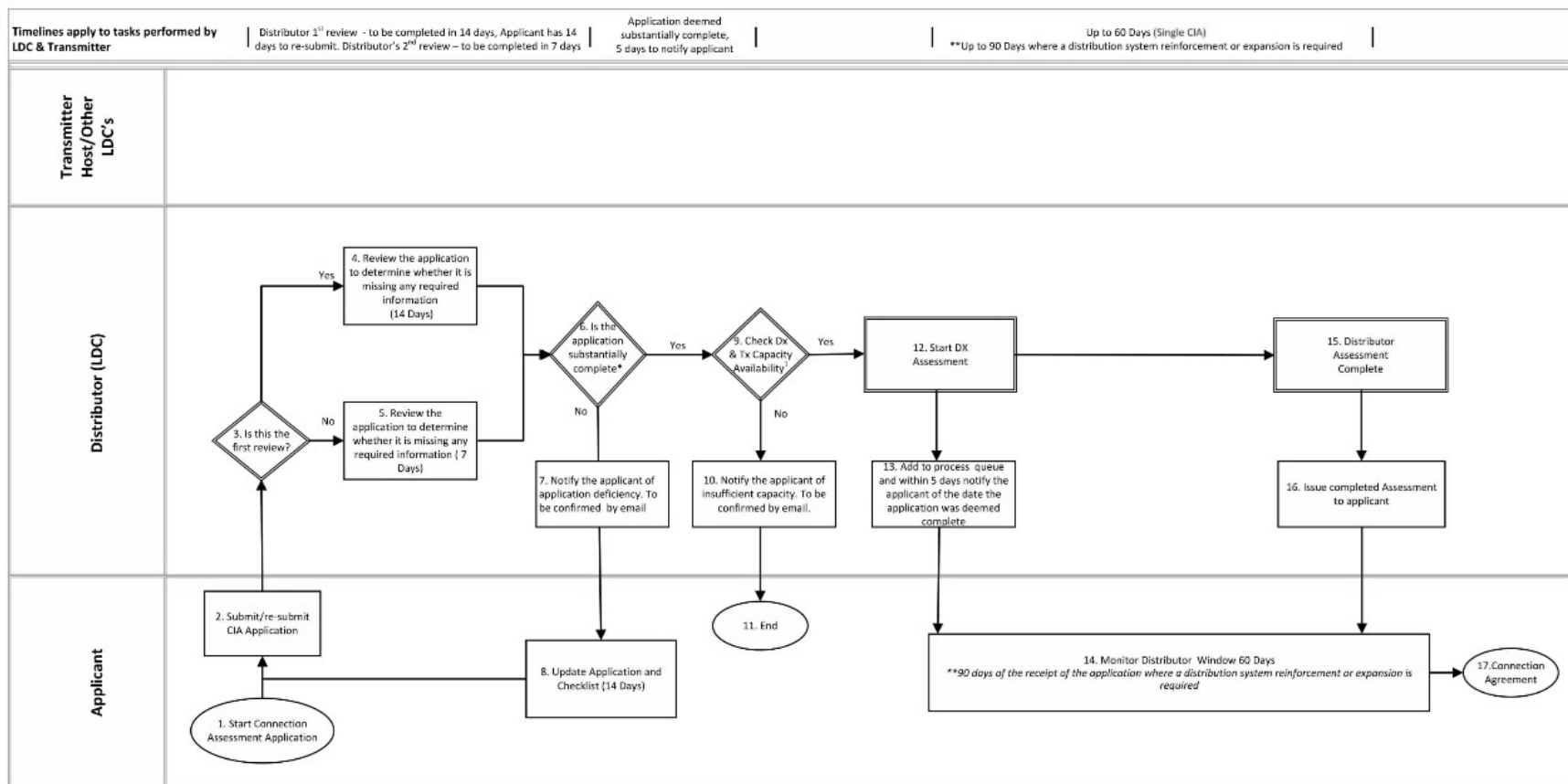

*An application for connection assessment is substantially complete when it contains information sufficient to allow a distributor to carry out its connection assessment activities

1. Check DX & TX Capacity gate is a secondary check to address system changes between the Pre-consultation phase and the CIA application.

Figure 4: Flowchart of Timelines and Responsibilities for Small Embedded Generation Facility Connections

Step 1. The applicant initiates the CIA process and gathers the current CIA application form and distributor's application requirements from the distributor.

Step 2. The applicant submits the completed CIA Application package, including completed application form, payment for required studies, attachments, and application checklist.

Step 3. The distributor determines if this is the initial submission or a revised application submission.

Step 4. For initial submissions, the distributor reviews the application for completeness within 14 calendar days.

Step 5. For revised application submissions, the distributor reviews the application for completeness within 7 calendar days.

Step 6. For the completeness check outlined in steps 4 and 5 above, the distributor will review the application to determine if there is sufficient information provided by the applicant to process the submission. Once the distributor determines that the submission provides the necessary information to commence a CIA study, the application is deemed substantially completed.

Step 7. For submissions that are not substantially complete, the distributor will notify the applicant of the application deficiencies via email or letter if the applicant's email is not provided. The deficiency notification shall identify any errors and omissions in the application that would prevent the distributor from proceeding with the CIA. The notification shall outline the available remedies required to have the application deemed substantially complete.

Step 8. On receipt of a deficiency notification, the applicant should review and revise the application to address the deficiencies and resubmit the application. The process allows 14 days for the applicant to resubmit a revised application. If the applicant does not return the revised application within 14 days, the distributor may remove the application from the processing queue. If the application is removed from the queue, it may be treated as a new application once it is resubmitted.

Step 9. For submissions that are deemed substantially complete, the distributor will reconfirm⁵ transmission and distribution capacity availability.

Step 10. The distributor will notify the DER applicant via email if there is no capacity available to support the connection.

Step 11. If there is no capacity available, the process concludes. .

Step 12. If capacity is confirmed to be available, the distributor proceeds with the assessment

⁵ This is a secondary check to address the possibility of system changes between the Preliminary Consultation phase and the CIA application.

Step 13. The distributor will add applications to the processing queue in the order in which they are deemed substantially complete and within 5 days will notify the DER applicant of the date the application was deemed substantially complete.

Step 14. The date the submission is deemed substantially complete starts the 60-day or 90-day window set out in Step 16, below.

Step 15. The distributor completes the CIA

Step 16. The distributor will provide with its CIA assessment a detailed cost estimate of the proposed connection and an offer to connect within:

- i. 60 days of the receipt of the substantially complete application where no distribution system reinforcement or expansion is required; or
- ii. 90 days of the receipt of the substantially complete application where a distribution system reinforcement or expansion is required

Step 17 The process moves onto the connection agreement phase.

5.7. Mid-sized / Large Embedded Generation Facility

Mid-sized and Large embedded generation facilities as classified in Table 1, are also subject to the screening process. Once they are deemed substantially complete, they will be assessed. The CIA process for the connecting distributor is essentially the same as for the small projects. If the connecting distributor is embedded in a host distributor, Mid-sized and Large embedded generation facilities must also have an assessment from the host distributor and a study from the upstream transmitter to assess the impact on the transmitter's system. Large projects also require a System Impact Study from the IESO to assess their impact on the IESO-administered grid. The flowchart in Figure 5 below shows the responsibilities of the various stakeholders and the expected task completion timeline. The distributor has responsibility for providing information to the upstream reviewers to ensure that the reviews occur as near to concurrently as is possible. In any case, the distributor is responsible for finishing its review within 60 days of the application being substantially complete for mid-sized embedded generation facilities and within 90 days of the application being substantially complete for large embedded generation facilities. Where a host distributor CIA is also required, these timelines will be increased by a further 15 days.

Connection Impact Assessment Process for Mid-sized or Large Embedded Generation Facility

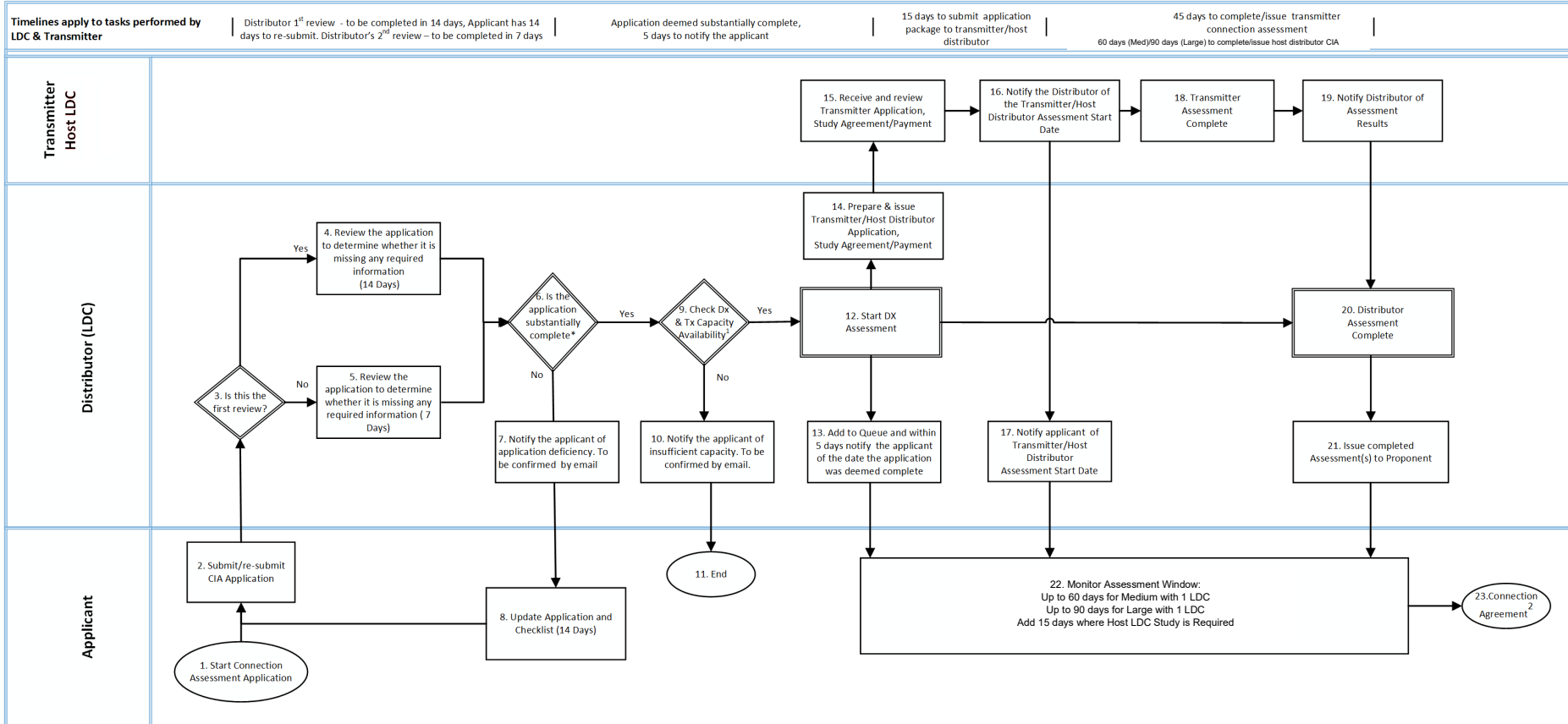

*An application for connection assessment is substantially complete when it contains information sufficient to allow a distributor to carry out its connection assessment activities

1. Check DX & TX Capacity gate is a secondary check to address system changes between the Pre-consultation phase and the CIA application.
2. After receiving capacity allocation CCA signed within (i) 17 months for large embedded generation facility if transmission upgrades are required, (ii) 9 months for large embedded generation facility if transmission system impact assessment required (iii) 6 months for all other embedded generation facilities (reference DSC 6.2.4.1)

Figure 5: Flowchart for CIA process for Mid-sized and Large Embedded Generation Facility Connections

Step 1. The applicant initiates the CIA process and gathers the current CIA application form and distributor's application requirements from the distributor.

Step 2. The applicant submits the completed CIA Application package, including completed application form, payment for required studies, attachments, and application checklist.

Step 3. The distributor determines if this is the first submission or a revised application submission.

Step 4. For initial submissions, the distributor reviews the application for completeness within 14 calendar days.

Step 5. For revised application submissions, the distributor reviews the application for completeness within 7 calendar days.

Step 6. For the completeness check outlined in Steps 4 and Steps 5 above, the distributor will review the application to determine if there is sufficient information provided by the applicant to process the submission. Once the distributor determines that the submission provides the necessary information to commence a CIA study, the application is deemed substantially completed.

Step 7. For submissions that are not substantially complete, the distributor will notify the applicant of the application deficiencies via email or letter if the applicant's email is not provided. The deficiency notification shall identify any errors and omissions in the application that would prevent the distributor from proceeding with the CIA. The notification shall outline the available remedies required to have the application deemed substantially complete.

Step 8. On receipt of a deficiency notification, the applicant should review and revise the application to address the deficiencies and resubmit the application. The process allows 14 days for the applicant to resubmit a revised application. If the applicant does not return the revised application within 14 days, the distributor may remove the application from the processing queue. If the application is removed from the queue, it may be treated as a new application once it is resubmitted.

Step 9. For submissions that are deemed substantially complete, the distributor reconfirms⁶ transmission and distribution capacity availability. Capacity is not reserved for the project until the CIA has been completed.

Step 10. The distributor notifies the applicant via email if there is no capacity availability to support the connection.

Step 11. If there is no capacity available, the process concludes.

Step 12. If capacity is confirmed to be available, the distributor proceeds with the assessment.

Step 13. The distributor adds the application to the processing queue and within 5 days notifies the DER applicant of the date the application was deemed substantially complete. The date the submission is deemed substantially complete starts the timed window for the distributor to return the completed CIA.

⁶ This is a secondary check to address the possibility of system changes between the Preliminary Consultation phase and the CIA application.

Step 14. The distributor prepares and issues an application to the transmitter for a CIA, a Study Agreement, and payment within 15 days of starting the assessment.

Step 15. The transmitter receives the application from the distributor along with the Study Agreement and payment. The Transmitter has 15 days to review the submission and notify the distributor

Step 16. The transmitter notifies the distributor of the Transmitter Assessment start date

Step 17. Distributor notifies the applicant of the Transmitter Assessment start date.

Step 18. The transmitter executes and completes the assessment within 45 days. Where possible the transmitter completes this study concurrently with the distributor Assessment.

Step 19. The transmitter notifies the distributor on the results of the assessment

Step 20. The distributor also completes its CIA

Step 21. The distributor will provide the completed CIA to the applicant within:

- i. 60 days of the receipt of the substantially complete application in the case of a proposal to connect a mid-sized DER; and
- ii. 90 days of the receipt of the substantially complete application in the case of a large DER.

The applicant can use the assessment start date notification to monitor the distributor's and transmitter's assessment progress against the applicable 60-day or 90-day assessment window. The assessment period is increased by 15 days where a host distributor assessment is also required.

Step 22. The process moves on to the connection agreement phase.

6. Agreements

Once the distributor and transmitter or host distributor have completed their respective CIAs, the process moves to the connection agreement phase. The DERCP provides process flowcharts and process steps for the connections of DERs to the distribution system. Please refer to Appendix E of the DSC for the Requirements for Connection Agreements. The OEB does not specify requirements for the form of Connection Cost Agreements and Connection Cost Recovery Agreements.

6.1. Connection Agreement

A Connection Agreement between a distributor and a generator contains specific terms and conditions relating to connection and access to the distributor's distribution system. Appendix E of the DSC contains the standard connection agreements for micro-embedded generation facilities. It sets terms and conditions for small embedded generation facilities, mid-sized embedded generation facilities and large embedded generation facilities.

6.2. Connection Cost Agreement

Description

The Connection Cost Agreement (CCA) sets out the scope of work and the associated cost the distributor will seek to recover from the Applicant to connect the project to the distribution system. Because the connection may also impact a host distributor or the transmission system, the host distributor will also require a CIA and CCA and the transmitter will require a transmitter study and its equivalent to a CCA in response to the proposed DER project. The transmitter equivalent to a CCA is a Transmitter Capital Cost Recovery Agreement (CCRA). Where there is a CCRA the distributor will include the costs of any transmission work in its CCA as it is the responsibility of the distributor to contract for and pay the transmitter then collect from the customer.

Figure 6 outlines the interaction between the applicant, distributor, and host distributor/transmitter when multiple assessments and agreements are involved. The process steps for the scenario outlined in Figure 6 are provided below.

Connection Impact Assessment: Dual CIA and CCRA/CCA

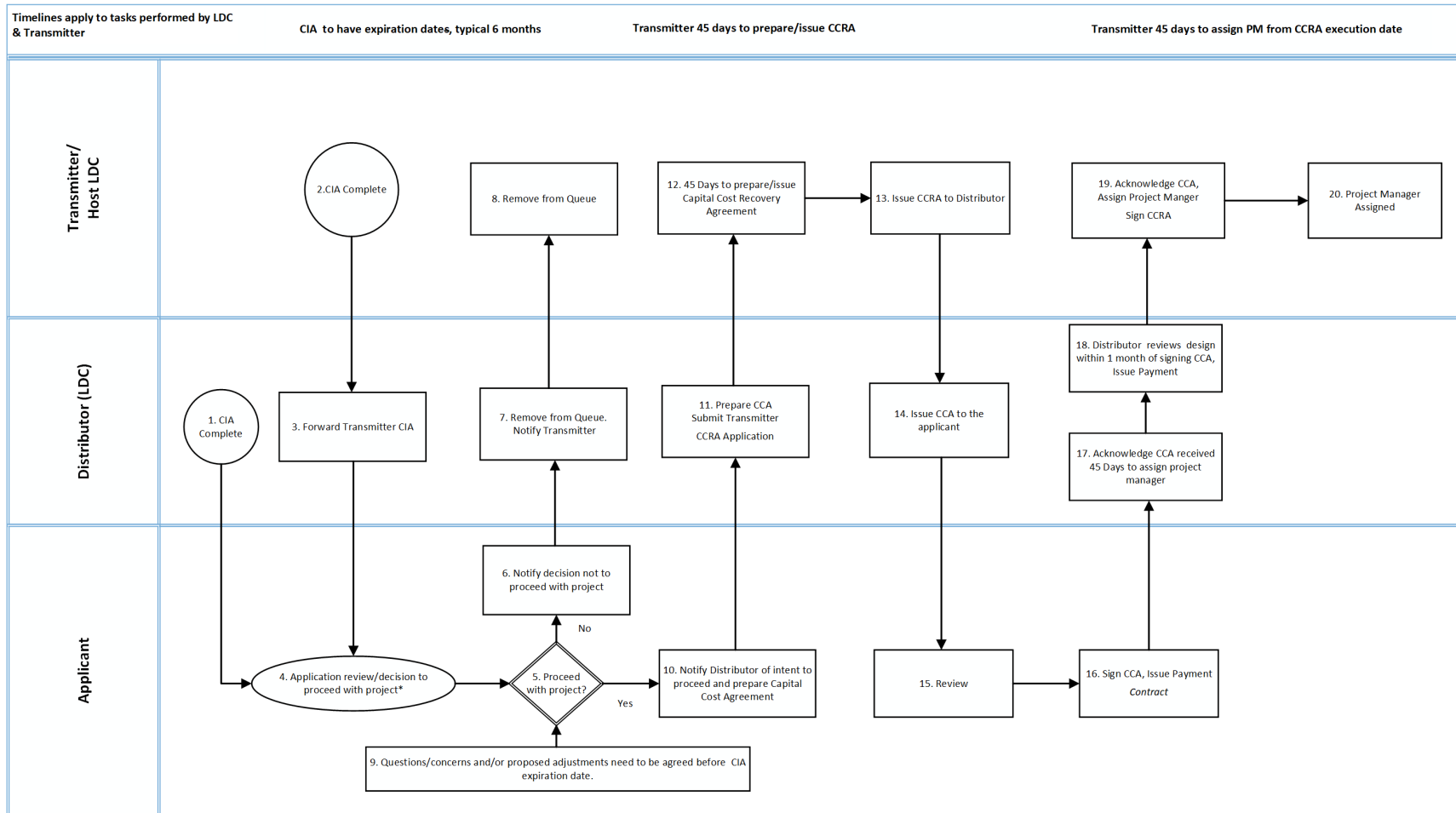

* For mid-sized and large generation facility applications, Applicants may elect to obtain a detailed cost estimate (process not shown in flow chart). This may require a new agreement between the applicant and the LDC, as well as associated fees.

Figure 6: Flowchart Outlining Interactions Between Parties (Multiple Connection Agreements)

Steps 1-3. The process starts with the applicant reviewing the completed CIA (s) from the distributor, the host distributor and if applicable, the transmitter.

Step 4. The applicant decides whether to cancel or proceed with the connection of the project

Step 6. The applicant notifies the distributor in the case of a decision not to proceed with the project.

Step 7. The distributor notifies the host distributor/transmitter that the applicant is not proceeding with the project. The distributor removes the project from the application processing queue and the process concludes for the distributor.

Step 8. The host distributor/transmitter removes the project from the application processing queue and the process concludes for the host distributor/transmitter.

Step 9. The applicant should discuss with the distributor any concerns, questions and/or proposed adjustments that need to be agreed upon before the Connection Assessments expiration date(s). An extension may be granted by distributor if deemed necessary.

Step 10. The applicant must notify the distributor of its intent to proceed with the Project.

Step 11. The distributor prepares the Capital Cost Agreement (CCA) and submits a Transmitter Capital Cost Recovery Agreement (CCRA) Application to the transmitter.

Step 12. The transmitter prepares the CCRA within 45 days.

Step 13. The transmitter issues this CCRA to the distributor.

Step 14. The distributor reviews the CCRA and issues the distributor's CCA to the applicant.

Step 15. The applicant is expected to review the CCA and seek any clarification from the distributor if required.

Step 16. If the applicant agrees with the terms of the CCA, the applicant sign and issues payment to the distributor.

Step 17. The distributor acknowledges receipt of the CCA, assigns a Project Manager within 45 days, issues payment to the transmitter, and executes the CCRA and any other required agreements.

Step 18. The distributor shall review the detailed design within 1 month of signing the CCA

Step 19. The transmitter acknowledges receipt of the CCRA and assigns a project manager within 45 days.

Step 20. The process moves onto the build phase after assignment of the Project Manager for the distributor and transmitter.

6.3. Connection Cost Responsibility (CCR)

Connection cost responsibility is covered in Chapter 3 and Appendix B of the DSC.

6.4. Option to Request a More Detailed Cost Estimate

As noted earlier, the outcome of a CIA includes: the technical requirements of the connection; and an estimate of costs. The cost estimate at this point is usually based on typical pricing and the distributor will indicate the anticipated level of uncertainty for the estimate. As described in section 5.1.4, an applicant for a mid-sized or large generation facility may request a detailed cost estimate, at the applicant's expense. The applicant has the option of paying for the detailed cost estimate which would be intended to reduce the level of uncertainty to a lower amount before deciding on the project and before signing a connection cost agreement.

6.5. Build and Energization Process

After the CCA is executed, the construction drawings are finalized, and the applicant can proceed to construction. A kick-off meeting is scheduled with an assigned project manager within 45 days of the CCA being signed. The Build and Energization process flowchart starts with the assignment of the distributor project manager at the end of the CCA phase. The full process flowchart is outlined in Figure 7. The corresponding process steps for the distributor, transmitter and Applicant follow thereafter.

Distributed Energy Resources Connection Build Process

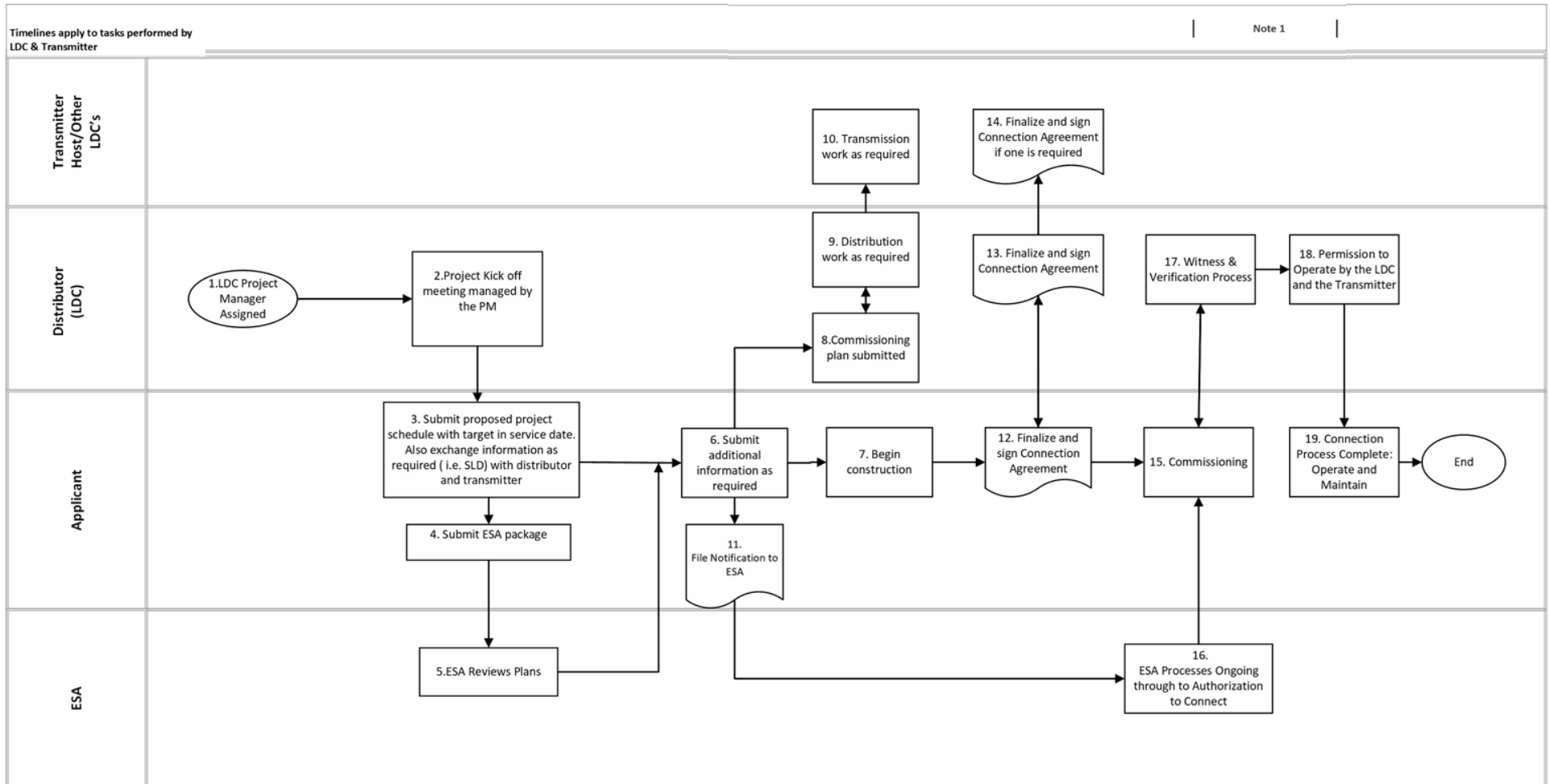

NOTE 1: Small (a) – up to 60 days when there is no distribution system reinforcement or expansion required to facilitate generator connection.
 Small (b) – up to 180 days when a distribution system reinforcement or expansion is required to facilitate connection
 Medium and Large - Negotiated during plan commitment

Figure 7: Flowchart for Build Process

- Step 1. The distributor assigns a project manager who will coordinate a project kick-off meeting with the applicant and the host distributor/transmitter.
- Step 2. The distributor's Project Manager will complete a project kick off meeting with all parties involved to discuss facility design, SLD, protections and controls, cost estimates and the project schedule including target in-service date.
- Step 3. Applicant is to provide project design details including single line diagrams (SLDs) and the proposed project schedule including targeted in-service date.
- Step 4. The DER Applicant must provide information to the ESA for the Plan Review process.
- Step 5. ESA reviews the Plan and provides feedback.
- Step 6. The Applicant shall, at transmitter's and distributor's request, provide a summary of testing results, including any certificates of inspection or other applicable authorizations or approvals certifying that any of the applicant's new, modified or replacement facilities have passed the relevant tests and comply with all applicable instruments and CSA C22.3 No 9.
- Step 7. The Applicant begins construction of the project.
- Step 8. The Applicant submits the Commissioning Plan to the distributor and the transmitter via the distributor.
- Step 9. The distributor completes any additional work required.
- Step 10. The transmitter completes any additional work required
- Step 11. The applicant files a notification with ESA.
- Step 12. The Applicant finalizes the terms of the Connection Agreement with the distributor and signs the agreement
- Step 13. The distributor finalizes the terms of the Connection Agreement with host distributor/transmitter if required and signs the agreement(s)
- Step 14. The host distributor/transmitter finalizes the terms of the Connection Agreement with the distributor and signs the agreement(s)
- Step 15. The applicant proceeds with commissioning and testing of the generation facility.
- Step 16. The ESA inspections through the construction process up to and including the issuance of an Authorization to Connect.⁷
- Step 17. The distributor witnesses and verifies the applicant's commissioning process related to the connection facilities.

⁷ ESA may issue a temporary Authorization to Connect according to its own processes.

Step 18. The distributor (and transmitter where and when applicable) will grant the applicant permission to operator once all the distributor connection requirements have been satisfied and ESA Authorization to Connect have been received by the distributor.

Step 19. The connection process concludes when the DER is fully connected and operational.

Table 2: Other Potential Agreements

Agreement Name	Parties	Purpose
Construction Agreement (e.g. Connection Cost Agreement)	Distributor, Generator	Describes obligations of the distributor and generator to complete connection, including terms of cost recovery.
Construction Agreement (e.g. Connection Cost Recovery Agreement)	Distributor, Transmitter	<u>As specified in the Transmission System Code:</u> In the event a transmission system requires modifications to connect the generator, this document describes the obligations of distributor and transmitter to complete the connection, including terms of cost recovery.
Conditions of Service	Distributor, Generator	In the event that the generator is a load customer of distributor, this document describes terms and applicable rates.
Additional Operations Agreement (if required) ⁸	Distributor, Generator	<u>Within limits of permission under of the DSC</u> Modifications as necessary to existing Connection Agreement to include provisions for safe and effective operation in presence of the generator on the distribution system.

⁸ Additional Operations Agreement(s) or Construction Agreement(s) may be required where other parties are affected by generation connection, e.g.: embedded distributors.

7. Glossary

Point of Common Coupling (PCC)

The point where the distributor's distribution system ends, and the new DER's connection assets or the existing load customer's connection assets begin. This is equivalent to the DSC definition for Point of Supply. The PCC is shown in Figure 8 and Figure 9, in relation to assets owned by the distributor (Local Distribution Company, LDC) and the customer.

Point of DER Connection (PODC)

The point where the DER connects with the DER's connection assets as outlined in Figure 8 and Figure 9.

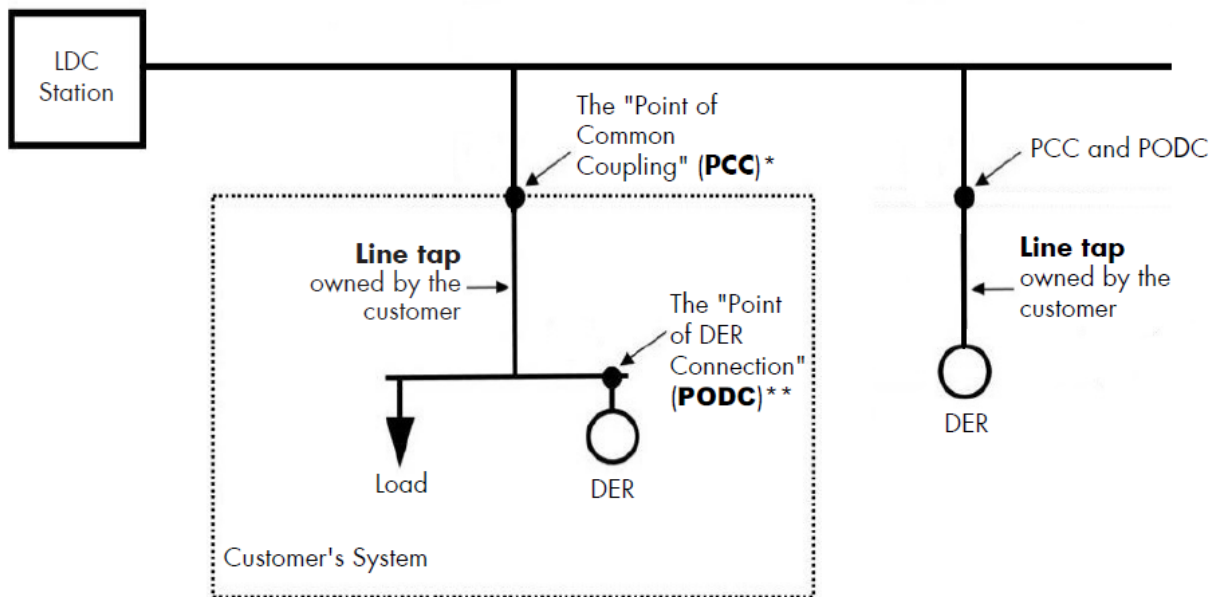

*PCC: the point where the customer facility connects to the LDC owned system

**PODC: the point where the DER unit(s)'s interconnection system connects the DER unit(s) to the DER facility.

Figure 8: PCC vs PODC (No New Distributor-Owned Line Expansion)

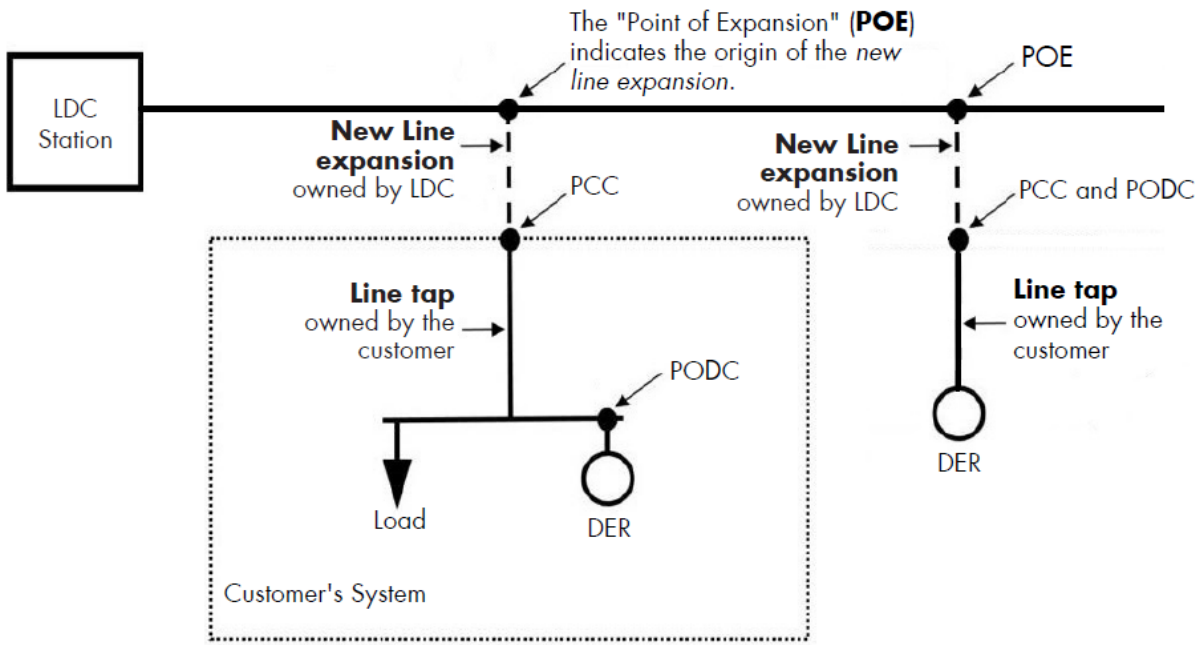

Figure 9: PCC vs PODC (With New Distributor-Owned Line Expansion)

8. Appendices

A. Sample Protection Philosophy

B. Single Line Diagrams

C. Standardized Form Templates

- I. Preliminary Consultation Information Request Template
- II. Preliminary Consultation Information Request Sample
- III. Preliminary Consultation Report Template
- IV. Preliminary Consultation Report Sample
- V. Connection Impact Assessment Application Template
- VI. Connection Impact Assessment Application Instructions
- VII. Connection Impact Assessment Application Sample

Appendix A – Sample Protection Philosophy for Battery Energy Storage System

Sample Protection Philosophy for Distributed Energy Resource Proponents Applying for Connection

This document is a summary of a sample protection philosophy for non-exporting, inverter-based (NE/I) connections including storage, solar, and wind. The OEB intends it as a guide for applicants regarding the kinds of protections, and particularly the categories of protections, that distributors will require for connection.

This is one example of a protection philosophy that would meet the requirements for a complete protection philosophy for the purpose of a CIA application⁹. Other philosophies may also meet the standards. It provides guidance to a distributed energy resource (DER) proponent on good utility practice as it relates to protection requirements of non-exporting, inverter-based (NE/I) DERs. To form a protection scheme, all the elements for each category within any given protection philosophy are requirements.

This document is not an approval for connection. This information should help applicants file better and more complete applications for connection. An applicant will need to submit detailed protection settings after the utility has completed the impact assessment of the submitted connection application.

The standards and certification testing referenced in this document should be read as referring to the current versions of these standards at time of reading.

Sample Protection Philosophy for Non-exporting Inverter-based Sources

Project Name:

Project ID#:

Project Type:

Capacity:

Connection feeder (optional):

In compliance with the technical interconnection requirements of the local distribution company for which this project will interconnect, the protection system of the connection will be designed to:

- Detect internal faults with the generator facility, downstream of the Point of Common Coupling (PCC), and automatically disconnect the NE/I source
- Detect external faults on the utility feeder and automatically disconnect the NE/I source
- Detect islanding conditions and disconnect the NE/I source
- Detect export of power from the NE/I source to the utility feeder and automatically disconnect the NE/I source

⁹The contents of this document, although intended as guidance, conform to the interconnection and approval requirements prevalent at the time of its issuance. At all times, the current versions of relevant codes and standards govern.

Internal Faults Within the Generator Facility

The following protections are in place to protect against internal faults resulting from the NE/I source:

- **Multi-Function Relay**-At the PCC, a multi-function relay will be installed to monitor internal faults resulting from the NE/I source. The 52 Trip Breaker will trip if it detects the following:
 - 25 - Synchronization Check
 - 27 - Undervoltage
 - 59 - Overvoltage
 - 81O/U - Under and Over Frequency
 - ID -Active Anti-Islanding
- **Inverter Breakers** - Each inverter is equipped with an AC breaker at the output of the inverter providing additional overcurrent protection
- **Facility Overcurrent Protection** -All circuits within the facility are protected from both phase-to-phase and phase-to-ground faults by appropriate overcurrent protection devices. Fuses are sized to clear under fault conditions within the generator facility

External Phase and Ground Faults in the Distribution System

The following protections are in place to protect against external faults resulting from the utility feeder:

- **Multi-Function Relay** - At the main utility service, prior to the first facility load, a multi-function relay will be installed to monitor faults from the utility feeder. The 52 Trip Breaker at the NE/I source PCC will trip under the following faults:
 - 27 - Undervoltage
 - 32R- Reverse Power
 - 50/51- Overcurrent
 - 59 - Overvoltage
 - 81O/U - Under and Over Frequency
 - 67 - Directional
- **Inverter Protection:** The inverters proposed for this project are certified to UL 1741, IEEE 1547, CSA C22.2 107.1-01 standards¹⁰ and will behave accordingly.

Anti-Islanding

- The Energy Resource Facility will operate in a grid following mode and will not operate islanded.
- **Anti-Islanding Inverters** -The NE/I source inverters contain both passive and active anti- islanding protection as required by IEEE 1547 and UL1741 SA. If the utility normal power supply is interrupted, the inverters detect the loss of power and disconnect.

¹⁰ All references to standards or testing certifications should be read as the most current version.

Reverse Power

- **Reverse Power Protection** - In addition to the multi-function relay at the utility supply monitoring reverse power (32R), the load is continually monitored to ensure the NE/I source discharge is below the consumption of the facility. This additionally protects against power injection to the utility grid.

Directional Overcurrent

- **Directional overcurrent protection** - Directional overcurrent relays are normally used on incoming line circuit breakers on buses which have two or more sources. They are connected to trip an incoming line breaker for fault current flow back into the source, so that a fault on one source is not fed by the other sources.

Special Comment Regarding Inverter Based Generation

The inverters specified for this project have a limited fault current contribution.

- Because inverters are current-limited devices, unlike rotating generators, the fault current is very close to the maximum output current, limiting the fault current in the system to 120% -140% of FLA.

Breaker Failure Scheme (Facilities with an aggregate output > 500kW)

In the event that 52-A fails to open when intertie protection relay calls for a trip, 52-B will instantaneously trip and lock out.

Reconnection

Manual reconnection: There is no automatic reconnection scheme at this facility. A manual reconnection will only be executed when given permission by the respective controlling authority.

OR

Automatic reconnection scheme: Intertie protection relay will initiate automatic reconnection of DER only after a fault event has occurred on the utility feeder and not after a fault event within the DER facility. Stable voltage and frequency measurement within ranges and for time period stipulated in the technical interconnection requirements will be met prior to automatic reconnection. Internal faults will be distinguished from external faults by pickup of directional overcurrent 67/67N protection element looking into DER facility. This will ensure reconnection into facility fault is prohibited by blocking of automatic reconnection scheme for facility faults.

Open Phase Protection

This project consists of multiple 1-phase inverters connecting to a 3-phase service or multiple 3-phase inverters connecting to a 3-phase service; therefore, open phase protection will be provided by 46 and/or 47 element(s) in the intertie protection relay to ensure the BESS maintains a balanced 3-phase output and detects loss of voltage in one or more phases and will trip the entire generating facility upon detection of such.

OR

Attached is a signed letter from the inverter manufacturer stating that a facility comprising of multiple inverters is capable of maintaining a balanced 3-phase output and will detect loss of voltage in one or more phases and will trip the entire generating facility upon detection of such.

Communications and Transfer Trip/DGEO (if applicable)

Summarize communication systems and transfer trip/DGEO timing (if applicable).

Table 1: Protection Summary Matrix

Description	IEEE Device	Internal Faults	External Faults	Anti-Islanding	Reverse Power	Trips 52-A	Trips 52-B	Disables Inverters
Over-Voltage	59	X	X	X		X		X
Under-Voltage	27	X	X	X		X		X
Over-Frequency	81O	X	X	X		X		X
Under-Frequency	81U	X	X	X		X		X
Instantaneous Over-Current Phase	50	X	X			X		X
Timed Over-Current Phase	51	X	X			X		X
Reverse Power	32R			X	X	X		
Breaker Fail	50BF						X	
Active Anti-Islanding	IEEE 1547			X				X

Table 2: Protection Elements

Protection Element Function	Device#	FeederProtection Relay/Shunt Trip	IEEE 1741 SA Inverter
Over-Voltage	59	X	Y
Under-Voltage	27	X	Y
Over-Frequency	81O	X	Y
Under-Frequency	81U	X	Y
Synchronization Check	25	X	Y
Reverse Power	32R	X	
Overcurrent	50/51	X	Y
Directional	67	X	
Active Anti-islanding	ID		X

X= Primary

Y = Secondary

Appendix B - Sample Single Line Diagram

Item Number	Information to Include
1	<p>The title block should include:</p> <ul style="list-style-type: none"> • The legal name of the facility owner • Facility address/location • Project purpose • LDC assigned project ID • Revision history
2	<ul style="list-style-type: none"> • State utility's distribution and transmission facility (station) name(s) • State the name of utility's station feeder to which the generator is connected • State the nominal distribution supply voltage (eg. 44kV) • State the information for the upstream and downstream switches closest to the PCC (nomenclature, type, etc.)
3	<ul style="list-style-type: none"> • LDC to assign nomenclature for this switch. <p>Note: initial submission can have the consultant/customer assigned nomenclature if a LDC designation is not yet available. Later, the customer is assigned a LDC designation, which should be added to the SLD and resubmitted to LDC before the SLD is considered finalized. The consultant/customer then has the option to replace the initial designation with LDC designation or keep both. Ensure the LDC designation is clearly marked to differentiate it from the consultant/customer designation (bolded, in brackets, etc). Item 3 has an example showing only LDC designation, while item 17 shows an alternate method that shows both designations. LDC only refers to the LDC designation when dealing with the customer. Example, when witnessing the switch used for work protection as per the LDC TIR. When submitting the new SLD with the changes, a higher revision number of the SLD should be used to track the changes. See SLD example.</p>
4	<ul style="list-style-type: none"> • The Point of Common Coupling (PCC) is the point of demarcation between LDC and the DER. It is the point where the DER is to connect to LDC's Distribution System. PCC demarcation point • LDC designated facility operating designation (NCXXXX) • If the nomenclature is not included, the SLD is considered incomplete.
5	<ul style="list-style-type: none"> • Fault indicators with directional functionality are required for each phase between the PCC and the first pole on the customer owned new line and should be visible from the PCC location.
6	<ul style="list-style-type: none"> • Provide the length(s), ownership, and size(s) of line(s) from PCC to the meter. This data is used for SSLA determination. The metering point is at the location of the CT's and not the physical meter. • To comply with LDC TIR
8	<ul style="list-style-type: none"> • State the number of CTs being used • State the CT ratios including both ratios if they are dual ratio • State the in-use CT ratio if dual ratio • State the ANSI/CSA CT accuracy class information (provide example on SLD after)

9	<ul style="list-style-type: none"> Clearly identify existing and new facility if applicable
	<ul style="list-style-type: none"> If a new equipment (ex. transformer) is being replaced in an existing facility, it should be indicated Ensure all existing generators or backup generators are shown
10	<ul style="list-style-type: none"> LDC designation must be shown Voltage rating Current rating Type of switch Single/3 phase Physically accessible to LDC <p>Alternatively, switch information can be shown on SLD as per item number 14</p>
11	<p>Fuse information to include:</p> <ul style="list-style-type: none"> Fuse rating Manufacturer make/model Fuse type on the SLD Example: S&C SMD-1A 50E TCC153
12	<p>Transformer Information to include:</p> <ul style="list-style-type: none"> Winding configuration LDC designation Manufacturer make/model Rating Ratio Transformer ownership
13	<ul style="list-style-type: none"> Please detail where the existing FIT/micro-FIT generator/meter are connected. Include LDC ID Show existing load Capacity Type <p>For new generators:</p> <ul style="list-style-type: none"> Show the generator(s) connection(s) to the power transformer(s) Show the operating nomenclature of the generator(s) (e.g. G1, G2, etc.) State the nameplate capacity of the generator or individual generators, where there is more than one, in kVA / MVA. or kW / MW For solar, state the size(s) and number of inverter(s) State the operating power factor (PF) State connection type (Wye, Delta, etc.) and indicate grounding State whether the generator is induction or synchronous type.
14	<p>This is an alternate way to item number 10 to show the information for a switch</p> <ul style="list-style-type: none"> LDC designation Voltage rating Current rating Indicate which device is compliant with isolation device requirements
15	<ul style="list-style-type: none"> To comply with LDC TIR
16	See item number 12

17	<ul style="list-style-type: none"> • LDC designation • Manufacturer make/model • Current rating • Single/3 phase <p>Note: initial submission can have the consultant/customer assigned nomenclature if a LDC designation is not yet available. Later, the customer is assigned a LDC designation, which should be added to the SLD and resubmitted to LDC before the SLD is considered finalized. The consultant/customer then has the option to replace the initial designation with LDC designation or keep both. Ensure the LDC designation is clearly marked to differentiate it from the consultant/customer designation (bolded, in brackets, etc). Item 3 has an example showing only LDC designation, while item 17 shows an alternate method that shows both designations. LDC only refers to the LDC designation when dealing with the customer. Example, when witnessing the switch used for work protection as per the LDC TIR. When submitting the new SLD with the changes, a higher revision number of the SLD should be used to track the changes. See SLD example.</p>
18	<ul style="list-style-type: none"> • The Point of DER Connection (POC) is the point where DER unit(s)'s interconnection system connects the DER unit(s) to the DER facility. • Depending on the facility, it can be the same as the PCC
19	<ul style="list-style-type: none"> • Include LDC Project ID # • Inverter manufacturer make/model • MW rating • IEEE/ANSI protection elements need to be noted for the customer's inverters • Include CSA Certification
20	<ul style="list-style-type: none"> • Manufacture make/model • MWh rating • Include information for gross load billing where required
21	<ul style="list-style-type: none"> • Teleportation equipment make/model • Flow of information/signals
22	<ul style="list-style-type: none"> • Relay manufacturer make/model • ANSI Device numbers used • Flow of information signals
23	Flow of signals between devices
24	<p>Other general information required:</p> <ul style="list-style-type: none"> • SLD must be stamped and signed by a Registered Professional Engineer in the Province of Ontario • All information on the SLD must be legible, and of a reasonably sized font for ease of reading • The Connection Impact Assessment provides details regarding the type and configuration of isolation devices required. • The DER facility must comply with all applicable interconnection requirements specified in the "Distributed Generation Technical Interconnection Requirements Interconnections at Voltages 50kV and Below" (TIR).

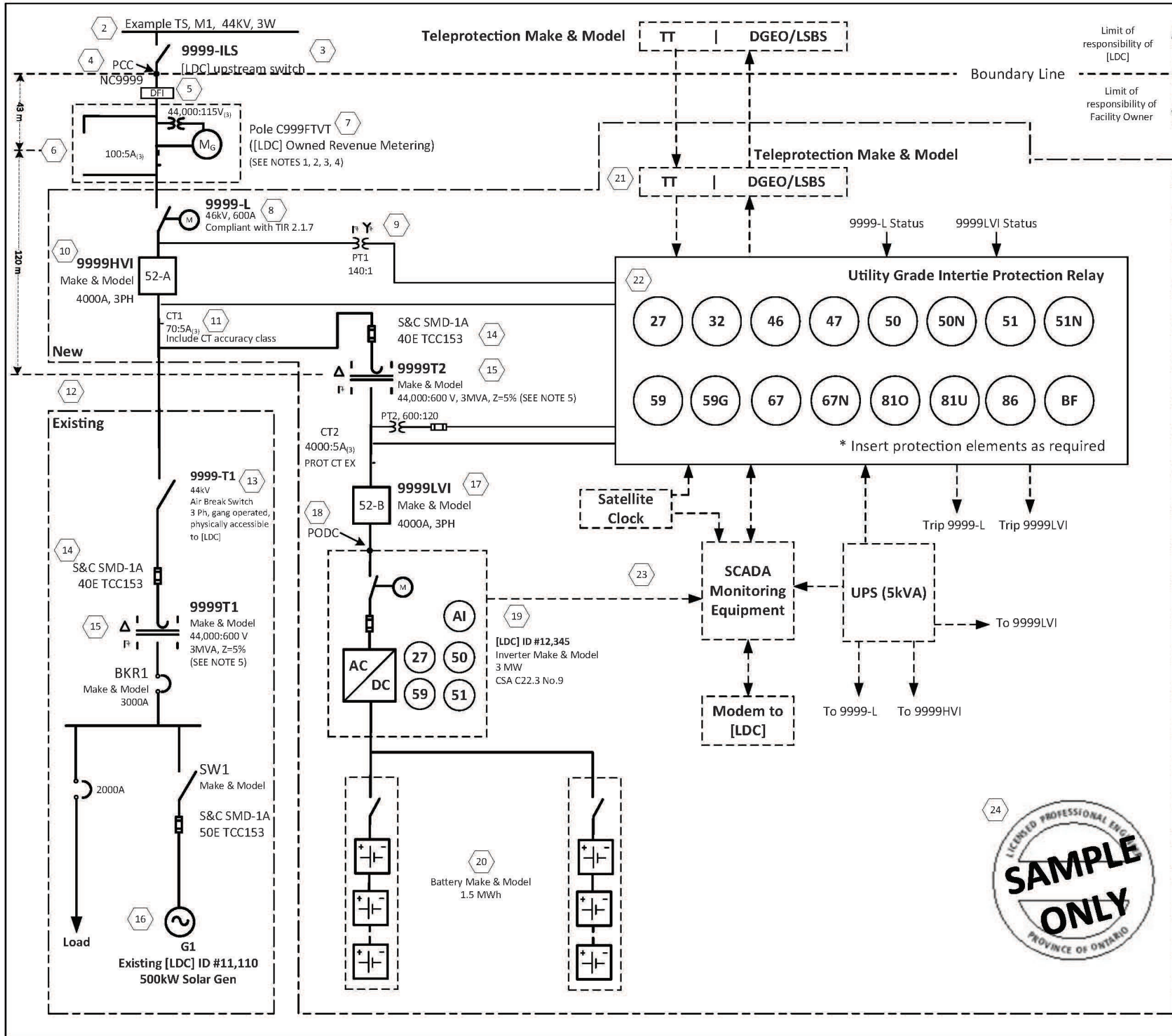

SLD CHECKLIST

The legal name of the facility owner, facility address/location, project purpose, [LDC] assigned project ID, and revision history should be included in the title block

See attached table for remaining important items.

Note, please do not include the hex markers on the official SLD submitted to [LDC]. They are shown here for illustration only

NOTES:

1. Colour code of the revenue metering instrument transformers secondary wiring shall match the overhead phase conductors
2. 100:5A, Measurement of Canada approved current transformer AE 1653, 0.15B0.9 CCRF=1.5
3. 44000:115V Measurement of Canada approved voltage transformer AE 2160r3, 0.3WXY, 200kV BIL
4. Compliant with Settlements & Revenue Metering SLD Requirements Revision 1.5.1
5. Transformer owned by ABC Inc

DISCLAIMER: This sample SLD shall only be used to highlight some of the main information that must be shown on the SLD submitted to [LDC]. All design decisions must be made by the proponent and meet the minimum requirement set forth in the TIR. Due to limited space, only some of the required items are shown. The rest of the information is indicated in the notes related to each number.

NO	REVISION/ISSUE	DATE
01	Revised as per {LDC} comments	18/11/2020
00	Initial SLD for [LDC] review	13/07/2020

PROJECT: Customer Name
Customer Address Line 1
Customer Address Line 2

Project Purpose

[LDC] Project ID: #12,345
Other Info

ABC Inc.
LOGO

ABC Inc.

DWG NAME: BEHIND THE METER EXAMPLE SLD

DATE: DD/MM/YYYY **DRAWN:** **CHECKED:**
18/11/2020 S. M. S. H.

DWG NO: 18/11/2020 **SHEET NO:** 1 of 1 **REV NO:** 01



Appendix C - Standardized Form Templates

- Preliminary Consultation Information Request Template
- Preliminary Consultation Information Request Sample
- Preliminary Consultation Report Template
- Preliminary Consultation Report Sample
- Connection Impact Assessment Application Template
- Connection Impact Assessment Application Instructions
- Connection Impact Assessment Application Sample